



ELECTRIFY RI

Level II Electric Vehicle Charging Station Incentive Program for Multi-Unit Dwellings



Guidance Document

*Version 1
October 31, 2019*



Table of Contents

1. PROGRAM OVERVIEW	3
2. ELIGIBILITY & LOCATION REQUIREMENTS	5
3. AVAILABLE FUNDING.....	7
4. ALLOWABLE COSTS	8
5. EV CHARGING STATION REQUIREMENTS	9
6. GENERAL PROGRAM REQUIREMENTS	10
7. ACCESSIBILITY REQUIREMENTS	11
8. APPLICATION AND INCENTIVE PAYMENT PROCESS	16
9. APPEALS PROCESS	19
10. CONTACT INFORMATION.....	19
Appendix A	20



1. PROGRAM OVERVIEW

In 2015, Volkswagen (VW) publicly admitted that it had secretly and deliberately installed a defeat device – software designed to cheat emissions tests and deceive federal and state regulators – in approximately 590,000 model year 2009 to 2016 motor vehicles containing 2.0 and 3.0 liter diesel engines. The United States Department of Justice (DOJ) filed a complaint against VW alleging that the company had violated the Clean Air Act. Subsequent federal court actions resulted in the State of Rhode Island receiving more than \$14 million from the Volkswagen Diesel Settlement (VW Settlement) Environmental Mitigation Trust (EMT). The purpose of the EMT is to execute environmental mitigation projects that reduce emissions of nitrogen oxides (NOx).

In August 2018, Rhode Island filed a Beneficiary Mitigation Plan (BMP) detailing how these funds would be invested to: a) achieve significant and sustained reductions in diesel emission in terms of tons of reductions in diesel emission exposures in areas designated as poor air quality areas, areas with historical air quality issues, and areas that receive a disproportionate quantity of air pollution from diesel fleets, and b) expedite development and widespread adoption of zero emission vehicles and engines. Specifically, *the BMP directs more than \$1.4 million to the Rhode Island Office of Energy Resources (OER) to support deployment of light-duty electric vehicle charging stations (also known as electric vehicle supply equipment or EVSE) throughout the Ocean State.*

To support greenhouse gas emissions reductions across the state’s transportation sector and encourage adoption of more sustainable transportation solutions by Ocean State residents and businesses, OER is allocating approximately \$712,000 of VW Settlement Funds to help deploy Level II EVSE throughout Rhode Island. **OER has reserved a minimum of \$150,000 for the Electrify RI Level II Multi Unit Dwelling Program.**¹

This Guidance Document details OER’s [Level II Electric Vehicle Charging Incentive Program for Multi-Unit Dwellings \(MUDs\)](#). Through this program, qualified multi-unit dwellings with five (5) or more residential units may be eligible for EVSE project incentives equal to the lesser of 60% of project costs or \$8,000 per station and \$16,000 per site location. For entities applying for incentives across multiple site locations, there is a total award cap of \$32,000.²

By installing electric vehicle charging stations, owners and operators of multi-unit dwellings:

- Provide residents the convenience of charging their vehicles at home;
- Demonstrate environmental leadership to residents, visitors, and the surrounding community;
- Improve the potential value and marketability of their multi-unit dwelling; and

¹ Multi-unit Dwellings (MUDs) include apartment complexes, condominiums, townhouses, etc. An “eligible location” consists of a unique street address in Rhode Island.

² Please see section 3 for full incentive amount details.



- Improve public commuting practices and reduce vehicle emissions of greenhouse gases and other pollutants, shrinking carbon footprints while improving air quality.

This guidance document provides additional information on program requirements and available incentives through this initiative.

Incentives will be reserved and awarded on a first come, first served basis, subject to availability of funding. Submission of an application does not guarantee funding and OER reserves the right to grant only a portion of the maximum allowable funding per project. Eligible applicants must meet all applicable requirements set forth in this document to qualify. OER reserves the sole right to extend, modify, or terminate this program based upon funding availability and/or other factors, as well as the right to recover any funding provided to an applicant and pursue any legal actions deemed appropriate if OER determines the applicant did not provide adequate or complete information or fails to meet the requirements or intent of the program.

Program incentives, combined with any other funding sources, cannot exceed 100% of the costs paid for the items listed in the **Allowable Costs** table (see Section 4).³ The applicant must commit to providing funds, either directly from the applicant or another source, to cover the remaining cost of the EV charging station, all of the installation costs, and operating and maintenance costs for a full consecutive five (5) years after charging station is operational.

All projects must be complete and operational within ninety (90) days of application approval by OER. A one-time extension of up to ninety (90) days may be requested to allow for unforeseen project delays, subject to approval by OER. For those projects that require new electric service and/or new construction projects, the ninety (90) days shall begin after the utility service activation is complete.

For more information on **Electrify RI**, please visit:
www.energy.ri.gov/electrifyri.php

³ This includes, but is not limited to, any incentives received from the National Grid’s Charging Station Demonstration Program or other sources.



2. ELIGIBILITY & LOCATION REQUIREMENTS

- a. Please review the requirements of R.I General Laws §31-21-18, Electric vehicle charging station parking restrictions, available at:
<http://webserver.rilin.state.ri.us/Statutes/TITLE31/31-21/31-21-18.HTM>.
- b. Property owners of Rhode Island-based multi-unit dwellings are eligible to apply for this program. MUDs include apartment complexes, condominiums, townhouses, etc. Eligible location consists of a unique street address.
- c. The MUD must include at least five (5) or more residential units at the site location.
- d. This program supports qualified, newly-installed electric vehicle charging equipment made operational after October 31, 2019.⁴ Stations that are resold, rebuilt, rented, leased, received from warranty insurance claims, or obtained as a gift or a prize, or new parts installed in existing stations, are not eligible.
- e. The applicant must certify that they will allow access to, and use of, electric vehicle charging equipment to all residents at the location identified in the application. **Applicants are encouraged to make their charging station(s) accessible to visitors and/or the general public, although it is not a requirement of this program.**
- f. For each port installed, one parking space must be designated for plug-in electric vehicle use only and marked clearly through visible signage.⁵ The grant recipient must actively enforce this requirement. Recipients are encouraged to paint the pavement to indicate the parking space is designated for EVs. Each station site shall have adequate parking to allow for the maximum number of vehicles that can be charged simultaneously.
- g. Applicant must have evidence of ownership of the location identified in the application or evidence that the installation is allowed on the property (i.e., written permission of owner and/or pertinent language in lease, license agreement, or easement. etc.) and provide such evidence upon request.
- h. The electric vehicle charging station parking space and area around the charging station must be maintained for useful and safe access by EV drivers (e.g. snow removal, general cleaning).
- i. The electric vehicle charging station parking space must be adequately lighted from dusk to dawn. The EVSE user interface must also be legible during both daytime and nighttime hours.

⁴ Please note that applicants intending to apply to National Grid's Charging Station Demonstration Program are required by the utility to select equipment listed on their eligible equipment list at:
<https://www.nationalgridus.com/media/pdfs/bus-ways-to-save/ee7387ev-equipment-list.pdf>.

⁵ For representative examples of EV charging station signage and parking space painting, please see Appendix A.



- j. Applicant must comply with all applicable federal, state, and local laws, ordinances, regulations, and standards, and with all federal, state, and local electrical and building codes for electric vehicle charging station installation and operation.
- k. Each electric vehicle charging station location shall be designed to protect equipment from physical damage. Measures may include, but are not limited to, curbs, wheel stops, setbacks, bumper guards, and bollards.
- l. Charging cords should not cross sidewalks or other pedestrian walkways that could create blockages, tripping hazards, or barriers to people with limitations in mobility.
- m. Directional signage to the electric vehicle charging station location must be installed, starting at the entrance to the parking area if the station is accessible to the general public.⁶
- n. A project may include more than one station at a site location.
- o. The applicant must comply with the *Accessibility Requirements* detailed in Section 7 of this document.

⁶ For representative examples of directional signage, please see Appendix A.



3. AVAILABLE FUNDING

Eligible EV Charging Station Equipment	Site Location	Incentive Amount
Level II	Multi-Unit Dwellings	<p>The lesser of 60% of project costs or caps of:</p> <p style="text-align: center;">\$8,000 per station and \$16,000 per site location</p> <p>For entities applying for incentives across multiple site locations, there is a total award cap of \$32,000.</p> <p>For project equipment, installation and/or operating and maintenance costs in excess of incentive caps, the applicant must commit to providing the balance – either directly from the applicant or another source – and ensure the station remains fully operational for at least five (5) consecutive years.</p>



4. ALLOWABLE COSTS

Examples of Allowable Costs include:	Examples of Costs <u>not</u> covered include:
<ul style="list-style-type: none"> • EVSE station equipment purchases • EVSE installation costs • Labor associated with site preparation • Power connection • Cable management strategy (e.g. coil, retractable, etc.) • Mounting and associated equipment for pedestal or wall • Separate payment module • Permitting • Design • Upgrading electrical supply (for safe EVSE operation only) • Striping • On-site signage • Warranty (first five-year period) • Networking/Software (first five-year period) • Protective devices (e.g. bollards) • Shipping/Freight 	<ul style="list-style-type: none"> • Real estate costs, such as purchase or rent • Capital costs not directly related to EVSE installation, such as construction of buildings or support parking facilities, etc. • Electricity consumption and demand charges • General post-installation operation and maintenance costs • Internet connection or cell signal • Networking/Software subscription (beyond first five-years) • Taxes • Warranty (beyond first five-years) • Any ancillary renewable (i.e. solar) or storage equipment

Note: OER reserves the sole right to review, accept, and/or deny all requests for allowable costs and it is the responsibility of the applicant to provide all necessary and requested information to OER to support its funding determination.



5. EV CHARGING STATION REQUIREMENTS

- a. Equipment must be a hard-wired Level 2 EV charging station.
- b. Must be certified by the Underwriters Laboratories, Inc. (UL), or equivalent safety standard.
- c. Must include all cables, connectors, interfaces, documentation for all components, and any other items necessary for full operation.
- d. Must be qualified to withstand extreme weather conditions, including temperature extremes, flooding, heavy rains, and high winds and is protected from malfunctions due to condensation.
- e. Have network monitoring for status (e.g. in-use, malfunction, etc.) fault reporting, energy consumption, and usage patterns.
- f. Each Level 2 site shall be equipped with a minimum of two (2) J1772-compliant charging ports.
- g. Must be able to charge EVs produced by multiple manufacturers.
- h. For charging stations that are equipped to accept payment, they must enable the payment option for all EV drivers without restrictions based on network membership or subscription (e.g., allow credit card without login).
- i. Must be a new installation of equipment ordered after an OER approval letter is received. Stations that are resold, rebuilt, rented, leased, received from warranty insurance claims, or obtained as a gift or a prize, or new parts installed in existing stations, are not eligible.
- j. Energy Star certification is recommended for all charging stations supported by this program.
- k. Must be installed by a Rhode Island licensed electrician in accordance with all National Electric Codes and the Rhode Island State Building Code – State Electrical Code.
- l. The applicant will obtain all appropriate permits and provide copies to OER upon request.



6. GENERAL PROGRAM REQUIREMENTS

- a. Must install and operate the EV charging station within ninety (90) days of the effective date of the contract with OER. A one-time extension of up to ninety (90) days may be requested to allow for unforeseen project delays, subject to approval by OER. For those projects that require new electric service and/or new construction projects, the ninety (90) days shall begin after the utility service activation is complete.
- b. Must operate and maintain the EV charging station for at least five (5) full consecutive years after the date the charging station is operational.
- c. The charging station must be operated as part of a network and support the following functions:
 - Must collect EV station usage data for at least five (5) full consecutive years after the date the charging station is operational. The applicant will report usage data to OER upon request, which shall include, at minimum, energy (kWh), demand (kW), the number of charging sessions, and fees collected. Data shared with OER will be anonymized and will omit personally-identifiable information;
 - Monitor station availability in near real time;
 - View stations on web portal or smart phone applications; and
 - Provide information for customer support when needed.
- d. The EV charging station must be registered with the United States Department of Energy's (DOE) National Renewable Energy Lab's Alternative Fuels Data Center at:
<https://afdc.energy.gov/fuels/electricity.html>

Applicants are also encouraged to submit the location to other EV charging websites such as www.PlugShare.com.
- e. Provide a customer support service number that is accessible to customers twenty-four (24) hours per day, seven (7) days a week through a toll-free telephone number that is clearly visible and posted on or near the charging station to assist customers with difficulties that accessing or operating the charging stations. The unit must be equipped with remote diagnostics and the ability to be "remote started." The customer support service must be capable of dispatching or otherwise providing services to address operational problems at the charging station. A customer who calls the toll-free number must get immediate assistance, including rebooting the system if necessary.
- f. The EV charging station should be operational at least ninety-five percent (95%) of the time.
- g. OER reserves the sole right to waive any of the requirements in this document, on a case-by-case basis, if an applicant requests such waiver in writing and provides proper support documentation requested by OER. The submittal of a formal request to waive a requirement does not guarantee that OER will grant such waiver.



7. ACCESSIBILITY REQUIREMENTS

Applicants who are required to provide handicapped accessible parking spaces within their parking area as required by the Fair Housing Act (42 U.S.C. 3601 et seq.), the 1991 or 2010 Americans with Disabilities Act Architectural Design Standards must meet the accessibility requirements for EV charging spaces as provided in this section.^{7 8}

According to the United States Department of Energy:

When designing ADA-compliant PEV charging stations, consider accessibility, ease of use, and safety for disabled drivers, including those using wheelchairs or other assistive equipment. Key considerations include ensuring adequate space for exiting and entering the vehicle, unobstructed access to the EVSE, free movement around the EVSE and connection point on the vehicle, as well as clear paths and close proximity to any building entrances.⁹

- a. Locations funded through this program must have at least 5% of the site’s EV charging spaces, but not less than one (1) such space, be accessible to persons with disabilities. If 5% calculates to a fraction, round the value up to the next whole number. This requirement is per parking area and is based on new plus existing EV charging spaces. The accessible EV charging spaces must be in addition to any ADA-required accessible parking spaces. For example:
 - A parking facility with 20 EV charging spaces or fewer requires at least 1 accessible EV charging space.
 - A parking facility with 21 to 40 EV charging spaces requires at least 2 accessible EV charging spaces.
- b. Accessible EV charging spaces can share the existing access aisle with existing “van-accessible” designated parking spaces within the parking lot.
- c. Accessible EV charging spaces may be used by anyone and do not have to be reserved for persons with disabilities.
- d. Accessible EV charging stations require an accessible route on both sides of the vehicle space that connects to the charging station for easier access. There must be a sufficient path

⁷ The best practices and minimum standards contained herein are derived from a number of sources, including siting and design guidelines produced by the United States Department of Energy, Clean Cities, the Transportation & Climate Initiative, and the Georgetown Climate Center, the United States Access Board, and the Massachusetts EVIP program. For more information, please review:

https://www.transportationandclimate.org/sites/default/files/EV_Siting_and_Design_Guidelines.pdf, https://afdc.energy.gov/files/u/publication/WPCC_complyingwithADArequirements_1114.pdf, <https://www.access-board.gov/guidelines-and-standards/buildings-and-sites/about-the-ada-standards/guide-to-the-ada-standards/chapter-5-parking>, and <https://www.mass.gov/files/documents/2019/09/10/massevip-wpc.pdf>

⁸ Note that, according to the U.S. Access Board, “If provided, accessible spaces at EV charging stations cannot count toward the minimum number of accessible car and van parking spaces required in a parking facility.” See: <https://www.access-board.gov/guidelines-and-standards/buildings-and-sites/about-the-ada-standards/guide-to-the-ada-standards/chapter-5-parking>.

⁹ https://afdc.energy.gov/files/u/publication/WPCC_complyingwithADArequirements_1114.pdf.



of travel to the EV charging station so that someone can exit their vehicle, access the EV charging station, return to their vehicle and get to their destination. Accessible EV charging spaces must include a parking space and striped access aisle(s) with a combined minimum width of 16’.

- A vehicle space of at least 10’-13’ is advisable. A 10’ parking width offers an extra 2’ that effectively provides a 5’ aisle on one side when paired with a minimum 3’ striped accessible route/aisle; a 13’ parking width will allow an 8’ aisle.
- There must be a clear space in front of the EV charging station of at least 30 inches x 48 inches.
- If the striped access aisles of the accessible EV charging station space abuts a sidewalk, there must be a curb cut to access the connecting sidewalk or route.
- Graphical representations and spacing suggestions are provided below. Note: the examples provided are not the only design options available and are meant as suggestions only.

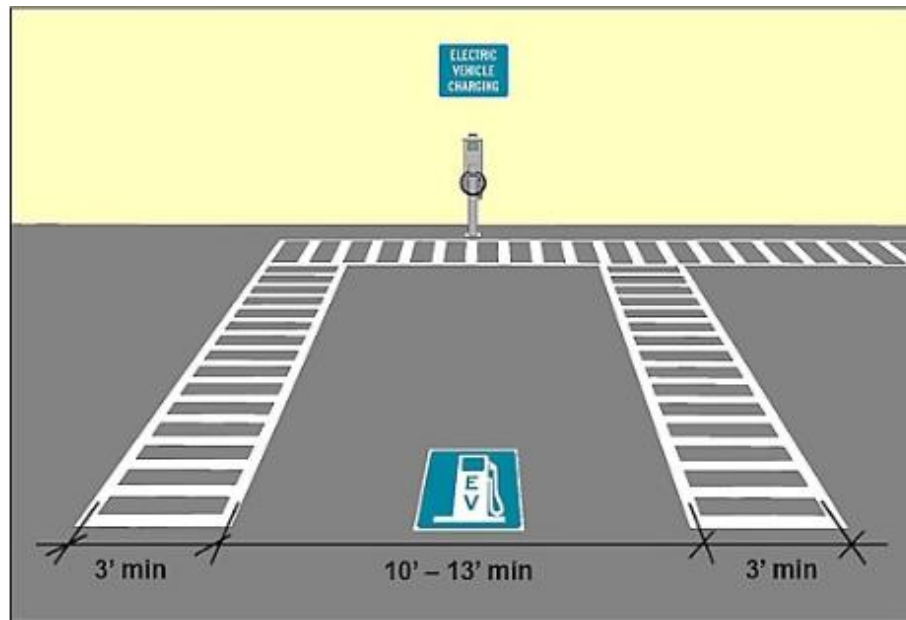

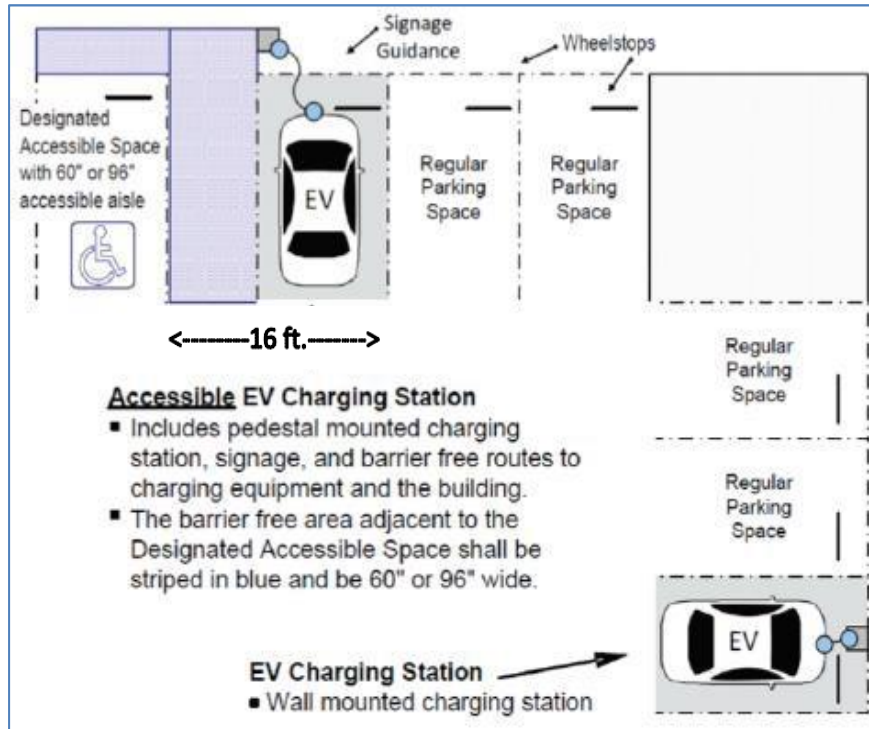

<i>Accessible EV Charging Space Examples</i>			
<i>Left Aisle Width</i>	<i>EV Charging Space</i>	<i>Right Aisle Width</i>	<i>Total Width</i>
3'	10'	3'	16'
3'	13'	3'	19'
5'	11'	0'	16'
0'	11'	5'	16'
8'	8'	0'	16'
0'	8'	8'	16'

- e. The ground surface for accessible EV charging spaces should be firm, level, and have a slope of no more than 2% in any direction. In addition, at the controls of the EV charging station, there must be a level landing (1:50/2%) measured in all directions.

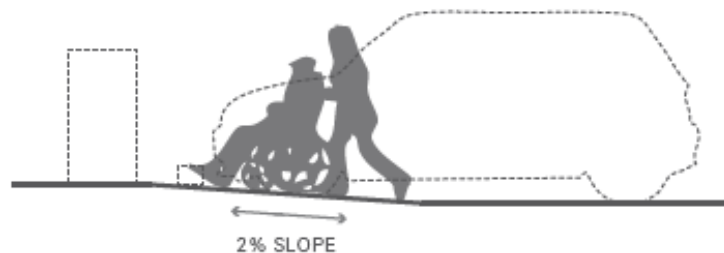

- f. Accessible EV charging spaces require a minimum of 8' 2" vertical clearance along the vehicular route to the parking space.



g. Controls and operating mechanisms shall be operable with one hand and shall not require pinching or twisting of the wrist.

h. Reach Ranges

- Forward reach: If the clear floor space only allows forward approach to the EV charging station, the maximum high forward reach is 48 inches and minimum low forward reach is 15 inches. See Diagram A below for forward reach drawing and reach clearances if the forward reach is over an obstruction.
- Side Reach: If the clear floor space allows parallel approach to the EV charging station, the maximum high side reach is 54 inches and the low side reach is no less than 9 inches above the floor. See Diagram B below for side reach drawing and reach and clearances if the side reach is over an obstruction.

Diagram A

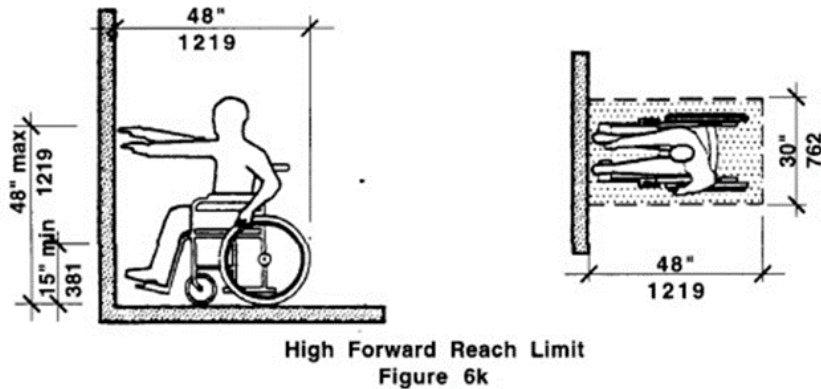

High Forward Reach Limit
Figure 6k

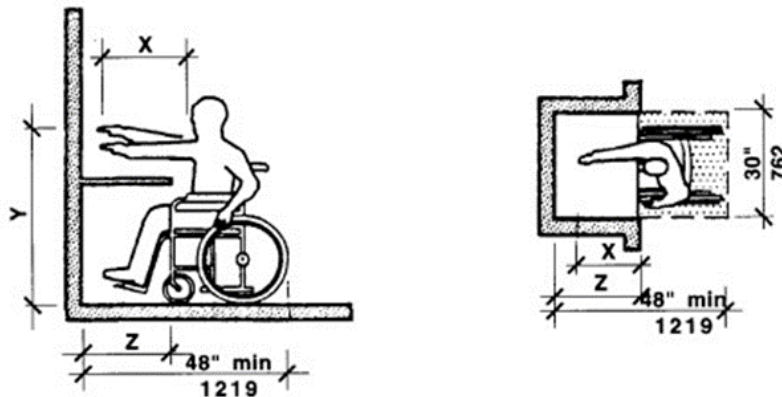

NOTE: X shall be less than or equal to 25" (635 mm). Z shall be greater than X.
When X is less than 20" (508 mm), then Y shall be 48" (1219 mm) max.
When X is 20" to 25" (508 to 635 mm), then Y shall be 44" (1118 mm) max.



Diagram B

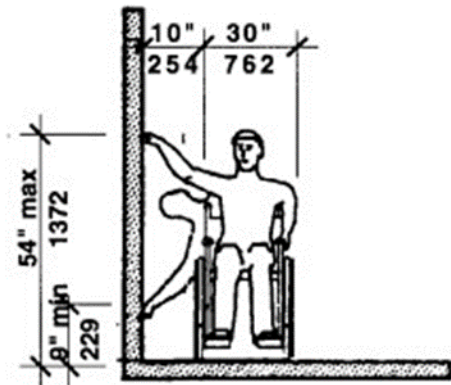

High and Low Side Reach
Figure 6m

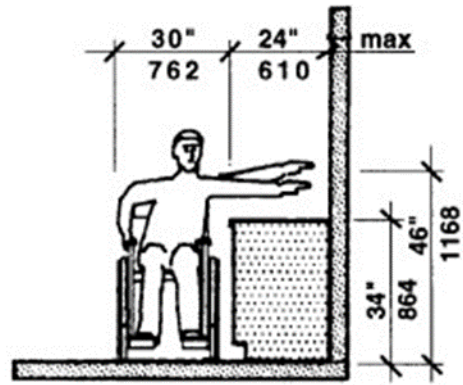

Maximum Side Reach over Obstruction
Figure 6n



8. APPLICATION AND INCENTIVE PAYMENT PROCESS

Applications will be processed on a first-come, first served basis until all available funding is expended or the program is terminated. Submission of an application does not guarantee funding and OER reserves the right to grant only a portion of the maximum allowable funding per project. Eligible applicants must meet all applicable requirements set forth in this document to qualify. OER reserves the sole right to extend, modify, or terminate this program based upon funding availability and/or other factors, as well as the right to recover any funding provided to an applicant and pursue any legal actions deemed appropriate if OER determines the applicant did not provide adequate or complete information or fails to meet the requirements or intent of the program.

The application and incentive payment process below assume the applicant has conducted its due diligence on identifying a viable site location for the electric vehicle charging equipment and selected a qualified vendor to design the project, procure equipment, install, and make operational the EVSE project, consistent with the requirements of this incentive program. OER is not liable and takes no responsibility for recommending/selecting qualified vendors; procuring necessary equipment; EVSE installation; or post-operational operations, maintenance, and/or warranty.

Step 1: Download and Submit a completed EV Charging Station Incentive Application

- Application forms and program guidance documentation can be downloaded at: www.energy.ri.gov/electrifyri.php.
- Completed application forms may be submitted electronically¹⁰ to DOA.ElectrifyRI@energy.ri.gov or by U.S. Mail to:

Rhode Island Office of Energy Resources
Attn: VW Program Administrator
One Capitol Hill – 4th Floor
Providence, Rhode Island 02908

- As part of the application process, entities will be required to disclose any other financial incentives related to the EV charging station project for which they have applied and/or received.

¹⁰ For all electronic submittals, please note that the State of Rhode Island security systems cannot fully secure and protect email transmittals to the State. Emails and associated attachments sent to the State is at your own risk.



Step 2: Application Review and Incentive “Reservation”

- OER will conduct a thorough review of the application submitted in Step 1. If a favorable determination is made, OER will issue an Approval Letter and associated contract documents, and “reserve” the requested incentive amount until project completion.
- Required contract documents include:
 - OER contract form; and
 - RI-W-9 Request for Taxpayer Identification Number and Certification.
- The Applicant (now a Grantee) will have thirty (30) days to return the signed contract documents to OER by email (DOA.ElectrifyRI@energy.ri.gov) or by U.S. Mail to the address above.
- OER will countersign the contract documents and return to the Grantee, within fifteen (15) days, to the email or physical address provided.

Step 3: Acquire, Install, and Make Operational EV Charging Station(s)

- From the effective date of the contract documents with OER, the Grantee will have ninety (90) days to complete EV charging station acquisition and installation and make the charging station operational.
- For those projects that require new electric service and/or new construction projects, the ninety (90) days shall begin after the utility service activation is complete.
- A one-time extension of up to ninety (90) days may be requested to allow for unforeseen project delays, subject to approval by OER.
- Requests for an extension must be submitted by email or U.S. Mail (see addresses above) to the Program Administrator no later than ten (10) business days prior to the initial ninety (90) day deadline.
- The Grantee will coordinate the delivery and installation of the charging station directly with the vendor.
- During all phases of procurement and installation, the Grantee must submit timely project updates upon request from OER.
- OER and/or their designated representative reserves the right to conduct site visits and inspection of the project before, during, and after charging station installation.



Step 4: Project Inspection and Payment of Eligible Incentives

- Upon successful installation and operation of the EV charging infrastructure, the Grantee must contact OER to request a site inspection. Note that OER will not process any payments to the Grantee until a site inspection is conducted and OER staff or its representative finds that there are no outstanding issues and the project was implemented consistent with all program requirements.
- Upon notification from OER that the project has been inspected and approved, the Grantee will be required to submit a completed payment request form (provided by OER) along with:
 - an itemized list of equipment;
 - copies of all final vendor invoices for the charging station and associated work;
 - copies of all required building and electrical permits;
 - copies of certificate(s) of inspection from the local city or town; and
 - any other related content requested by OER.
- The completed payment request form and informational packet should be signed and dated by an authorized agent. PDF Scanned copies of all final documentation may be emailed to DOA.ElectrifyRI@energy.ri.gov or submitted in hard copy form by U.S. Mail to:

Rhode Island Office of Energy Resources
Attn: VW Program Administrator
One Capitol Hill – 4th Floor
Providence, Rhode Island 02908

- Upon receipt, OER will review the submitted materials for completeness and, if approved, will make payment to the applicant for the authorized incentive amount. It may take up to seventy-five (75) days for the payment to be processed and paid.

Please note that program funding, combined with any other funding sources, cannot exceed 100% of the costs paid for the items listed in Section 4 – Allowable Costs. This includes, but is not limited to, any incentives received by the applicant from the National Grid’s Charging Station Demonstration Program or any other incentive program.



9. APPEALS PROCESS

The Commissioner of the Office of Energy Resources will consider appeals related to the denial of an application on a case-by-case basis. A request for appeal must be submitted, in writing, within thirty (30) days of the date of application denial to:

Commissioner of the Office of Energy Resources
Attn: VW Incentive Program
Office of Energy Resources
1 Capitol Hill, 4th Floor
Providence, Rhode Island 02908

10. CONTACT INFORMATION

For general questions and inquiries regarding the Electrify RI Program, please contact Sara Canabarro at (401) 574-9119 or DOA.ElectrifyRI@energy.ri.gov.

For more information on clean energy and transportation programs and solutions, please visit the OER website at: www.energy.ri.gov/.



Appendix A

Representative Examples of Charging Station Signage and Parking Space Painting

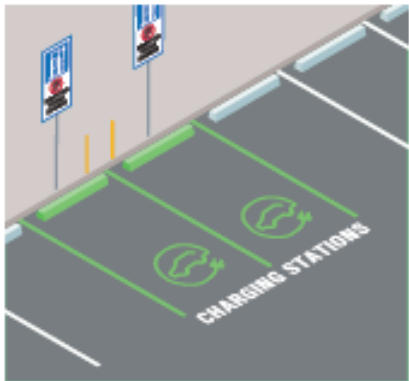

FIGURE 11.
PAVEMENT MARKINGS
EFFECTIVE WAYS OF CLEARLY
DESIGNATING SPACES FOR
ELECTRIC VEHICLE CHARGING.

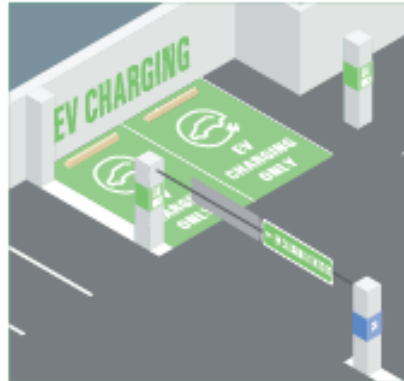

FIGURE 12.
WALL MARKINGS
PARKING GARAGES OFFER MANY
SURFACES FOR SIGNAGE TO BE
ATTACHED OR PAINTED.



FIGURE 13.
WAYFINDING SIGNAGE
DIRECTS DRIVERS TO EV CHARGING
STATIONS AND CAN INDICATE WHAT
TYPE OF EVSE IS AVAILABLE.

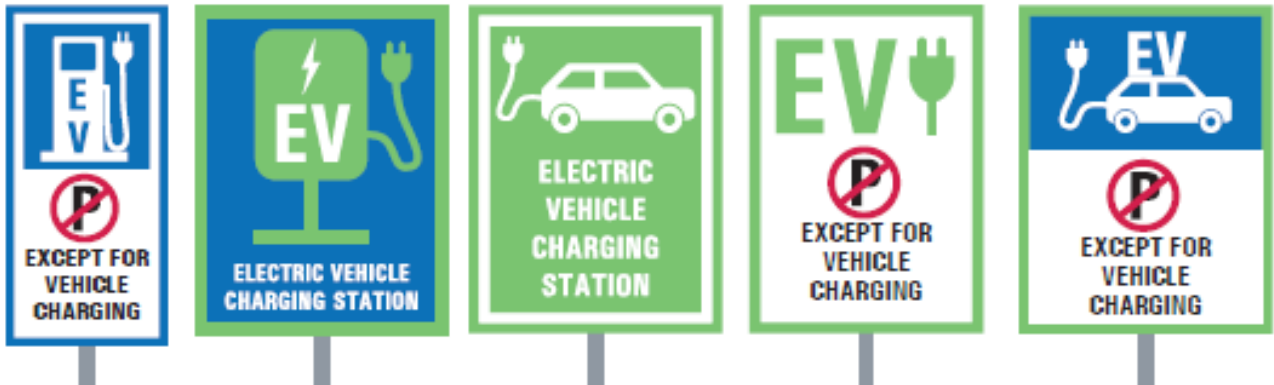

FIGURE 14.
EV-ONLY SIGNAGE EXAMPLES

A COMBINATION OF SYMBOL AND TEXT IS RECOMMENDED. THE TERM "CHARGING" SHOULD BE USED TO ENSURE HYBRID VEHICLES DO NOT USE THE SPACES FOR PARKING. THE SELECTED ELECTRIC VEHICLE SYMBOL SHOULD BE LARGER AND MORE PRONOUNCED THAN THE NO-PARKING SYMBOL TO AVOID CONFUSING MESSAGES.